

GARMIN®

MSC 10 ИНСТРУКЦИИ ЗА МОНТАЖ НА МОРСКИ САТЕЛИТЕН КОМПАС

Важна информация за безопасност

⚠ ВНИМАНИЕ

ЗАБЕЛЕЖКА

Когато пробивате или режете, винаги проверявайте какво има на противоположната страна на повърхността, за да избегнете повреда на съда.

MSC 10
2000. NMEA 2000,
garmin.com/manuals/nmea_2000. NMEA

Необходими инструменти

-
- 19 mm ($\frac{3}{4}$ in.)
- 5 mm ($\frac{3}{16}$ in.)
- 25 mm (1 in.)
- #2 Phillips
- 35 mm ($1\frac{3}{8}$ in.)
-
-
- 7 mm ($\frac{9}{32}$)
- NMEA 2000



Съображения за монтиране на компас

GPS, MSC 10 ()

1 OD, 14 ()

①



②

③

(EMI)

④

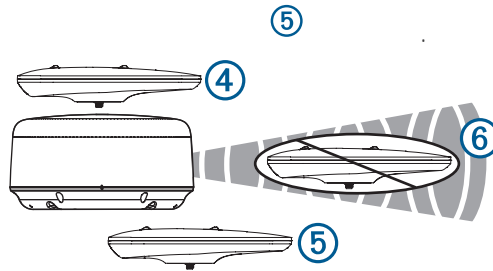

⑥

1 m (3) VHF

⑦

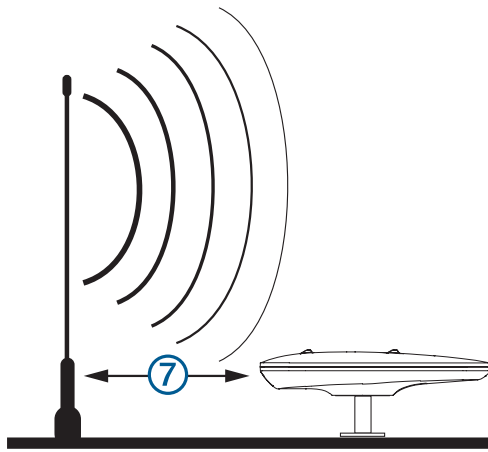

() ,

-
-
-

Повърхностен монтаж на компаса

- 1 $1\frac{3}{16}$ mm (in.) (). M4 x .07 x 45 5 $30\frac{3}{16}$ ()
- 2 5 $\frac{3}{16}$ in.)
- 3 25 (1)
- 4 ①

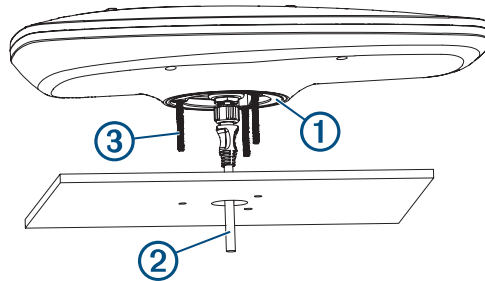

- 5 ②
- 6 ③
- 7 35 mm (1 $\frac{3}{8}$ in.)
- 8 ④
- 9 ⑦, ⑧, ⑤, ⑥

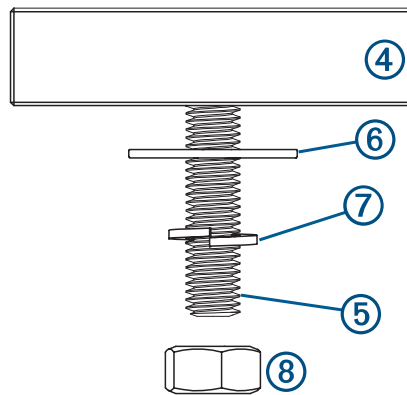

- 10 13,7 18,6 N-m (10 14 lbf-ft).
- 11

Монтиране на компаса на прът

OD, 14 ()

Монтиране на компаса с кабел, прокаран извън полюса

- 1
 - 2
- ①

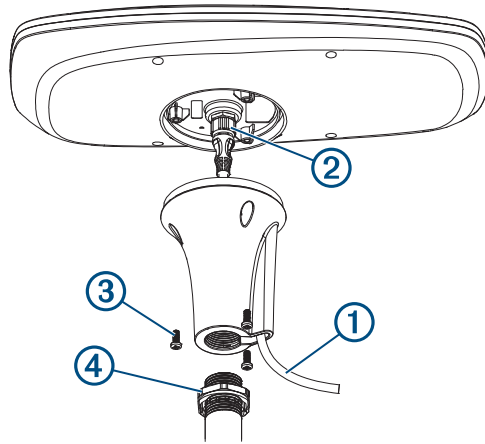

- 3
 - 4
 - 5
 - 6
 - 7
 - 8
 - 9
 - 10
 - 11
 - 12
 - 13
- ②
- ③ M4,
- ④
- 35 mm (1 3/8 in.)
- 1/4,
- ()

Свързване на компаса

NMEA 2000 Мрежова връзка

NMEA 2000,
NMEA 2000
NMEA 2000 T-
6 (20).
NMEA 2000.

NMEA 2000
garmin.com/manuals/nmea_2000.
NMEA 2000
NMEA 2000.

NMEA

2000 backbone,

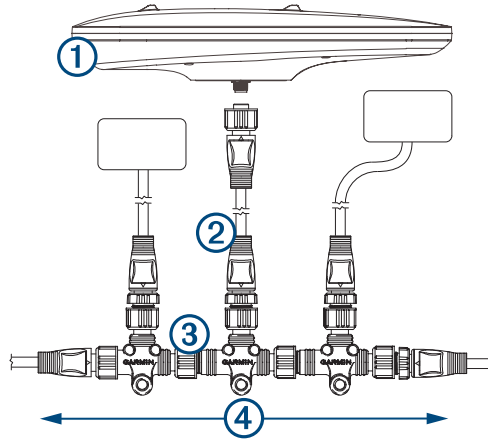

①	MSC 10
②	NMEA 2000 drop cable
③	NMEA 2000 T-connector
④	NMEA 2000 backbone

Калибриране на посоката

GPS

GPS

()

- NMEA 2000
- Garmin
- Garmin,
- NMEA 2000

Извършване на основно калибриране

NMEA 2000

Garmin

NMEA 2000

6,4 km / h (4 mph),

- 1
- 2
- 3
- 4
- 5

GPS
NMEA 2000

(COG)

NMEA 2000.

①

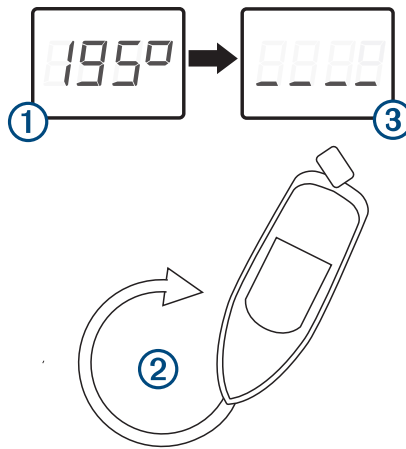

6

②

③

7

⑤

④

.1¹/₂

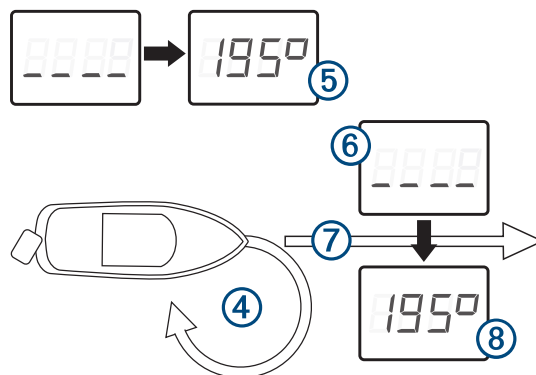

8

9

10

6,4 km / h (4 mph),

11

Настройки на компаса

NMEA 2000

MSC 10

Auto Locate:

Factory Defaults:

Почистване на външната обвивка

ЗАБЕЛЕЖКА

1

2

Допълнение

Актуализация на софтуера

Garmin,

support.garmin.com.

Спецификации

(length × width × height)	334 × 156 × 66 mm (13 ⁵ / ₃₂ × 6 ⁹ / ₆₄ × 2 ¹⁹ / ₃₂ in.)
	810 g (28.6 oz.)
NMEA 2000 drop cable	6 m (19 ft. 8 in.)
	From -15° to 70°C (from 5° to 158°F)
	From -40° to 85°C (from -40° to 185°F)
	ASA (Acrylonitrile styrene acrylate)
	IPX7
	0 mm (0 in.)
	9 to 16 Vdc, unregulated
	275 mA @ 9 Vdc
	180 mA @ 12 Vdc
NMEA 2000	LEN @ 9 Vdc 6
Typical NMEA 2000 draw	2W
Max. NMEA 2000 draw	2.5W

